

## 20' CONTAINERS

### Dry Container

**Maximum Payload Wt.:**  
38,000 lbs | 17,236 kgs

**Tare Weight:**  
5,290 lbs | 2,400 kgs

**Capacity:**  
1,172 ft<sup>3</sup> | 33.2 m<sup>3</sup>



### Internal Dimensions

Length: 20' 0"  
Width: 8' 0"  
Height: 8' x 6"

### Open Top

**Maximum Payload Wt.:**  
38,000 lbs | 17,236 kgs

**Tare Weight:**  
5,140 lbs | 2,330 kgs

**Capacity:**  
1,148 ft<sup>3</sup> | 32.5 m<sup>3</sup>



### Internal Dimensions

Length: 19' 4"  
Width: 7' 8"  
Height: 7'10"

### Flat Rack

**Maximum Payload Wt.:**  
68,000 lbs | 30,844 kgs

**Tare Weight:**  
6,170 lbs | 2,800 kgs

**Capacity:**  
- ft<sup>3</sup> | - m<sup>3</sup>



### Internal Dimensions

Length: 20' 0"  
Width: 8' 0"  
Height: 8' 6"

## 40' CONTAINERS

### Dry Container

**Maximum Payload Wt.:**  
44,000 lbs | 19,958 kgs

**Tare Weight:**  
8,820 lbs | 4,000 kgs

**Capacity:**  
2,385 ft<sup>3</sup> | 67.5 m<sup>3</sup>



### Internal Dimensions

Length: 40' 0"  
Width: 8' 0"  
Height: 8' 6"

### Open Top

**Maximum Payload Wt.:**  
44,000 lbs | 19,958 kgs

**Tare Weight:**  
8,950 lbs | 4,060 kgs

**Capacity:**  
2,327 ft<sup>3</sup> | 65.9 m<sup>3</sup>



### Internal Dimensions

Length: 40' 0"  
Width: 8' 0"  
Height: 8' 6"

### Flat Rack

**Maximum Payload Wt.:**  
76,000 lbs | 34,473 kgs

**Tare Weight:**  
10,800 lbs | 4,900 kgs

**Capacity:**  
- ft<sup>3</sup> | - m<sup>3</sup>



### Internal Dimensions

Length: 38' 4"  
Width: 8' 0"  
Height: 8' 6"

## 40' HC CONTAINER

### Dry High Cube

**Maximum Payload Wt.:**  
42,000 lbs | 19,050 kgs

**Tare Weight:**  
9,260 lbs | 4,200 kgs

**Capacity:**  
2,690 ft<sup>3</sup> | 76.2 m<sup>3</sup>



### Internal Dimensions

Length: 40' 0"  
Width: 8' 0"  
Height: 9' 6"

## 45' HC CONTAINER

### Dry High Cube

**Maximum Payload Wt.:**  
40,000 lbs | 18,143 kgs

**Tare Weight:**  
10,858 lbs | 4,870 kgs

**Capacity:**  
3,040 ft<sup>3</sup> | 86 m<sup>3</sup>



### Internal Dimensions

Length: 45' 0"  
Width: 8' 0"  
Height: 9' 6"

## MAIN DECK PALLET

### 96" Pallet

Equivalent to IATA Type 2BG

**Maximum volume:**  
21.2 cu.m (747 cu.ft.)

**Maximum gross weight:**  
6,804 kg (15000 lb)

**Can be loaded to:**  
96" (162 cm) and 118" (300 cm) on freighters

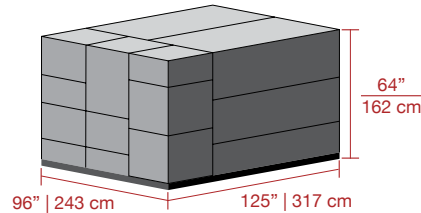

### 88" Pallet

Equivalent to IATA Type 2BG

**Maximum volume:**  
11.9 cu. m. (420 cu. ft)

**Maximum gross weight:**

- 747/DC-10: 6033 kg (13300 lb)
- 767: 5103 kg (11227 lb)
- 777/DC-10: 4626 kg (10501 lb)

**Can be loaded to:**  
96" (162 cm) and 118" (300 cm) on freighters

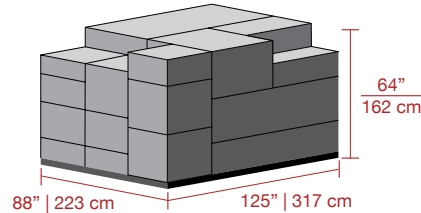

## LOWER DECK PALLET

### Half Pallet

Equivalent to IATA Type 6

**Maximum volume:**  
21.2 cu.m (747 cu.ft.)

**Maximum gross weight:**  
6,804 kg (15000 lb)

**Can be loaded to:**  
96" (162 cm) and 118" (300 cm) on freighters

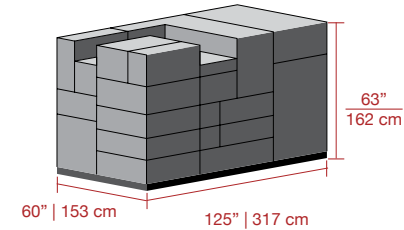

### 20' Pallet

Equivalent to IATA Type 1P

**Maximum volume:**  
33.2 cu. m (1174cu. ft.)

**Maximum gross weight:**  
11340 kg (25000 lb)

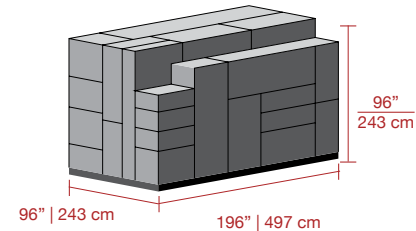

## LD-3

Equivalent to IATA Type 8

**Internal volume:**  
4.3 cu. m (152 cu. ft)

**Maximum gross weight:**  
1588 kg (3500 lb)

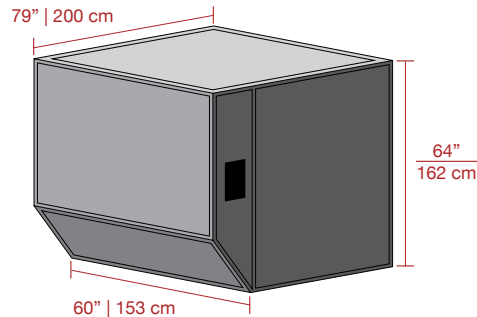

## LD-11

Equivalent to IATA Type 6

**Internal volume:**  
7.2 cu. m (253 cu. ft)

**Maximum gross weight:**  
3176 kg (7002 lb)

